



单轴 shredder WT2260 配螺旋输送  
Single shaft shredder WT2260 with screw loader



塑料破碎清洗回收线  
Plastic crushing & washing line



管材 shredder WT4080 简易破碎线  
Pipe shredding system WT4080 recycling Line



单轴 shredder WT40150 + 破碎机 PC52120 生产线  
Single shaft shredder WT40150 with Granulator PC52120



单轴 shredder WTF40120 配磁选生产线  
Single shaft shredder WTF40120 with magnetic separation



薄膜破碎清洗生产线  
Film shredding & washing system



SHREDDING EQUIPMENT CHINA 3E  
撕碎设备 · 中国 3E



SINGLE SHAFT SHREDDER

单轴 撕碎机



Domestic sales  
国内销售热线Tel:86-(0)20-39960299

Oversea sales  
海外销售热线Tel:86-(0)20-84729983

2023年1月印刷

广州市联冠机械有限公司 GUANGZHOU 3E MACHINERY CO.,LTD  
中国·广州市番禺区大龙街泰安路西六横街4号 No.4 XI LIU HENG STREET,TAIAN ROAD,DALONG,PANYU DISTRICT,GUANGZHOU,CHINA  
Webstie: www.3e-machinery.com / www.3e-recycling.com



3E机械官网



公司微信



## 应用 | APPLICATIONS



### 塑料制品 Plastics

薄膜Film /吨袋Woven Bag /PET瓶PET Bottle /塑料桶Plastic Barrels /管材Plastic Pipe/ 塑料板Plastic boards等



### 硬质塑料 Hard Plastics

胶头料Plastic lump(purgings) /纤维Fiber/高强度工程塑料 High strength engineering plastic ( ABS, PC, PPS and etc )



### 木材 Wood

圆木Timber/ 树根Tree root /木托板Wood Pallets



### 电线电缆 Coble



### 纸张 Paper



### 轻金属 Light Metal

易拉罐Aluminum can, 铝屑Aluminum scrap等



### 大型家电 White Goods

电视机外壳 TV Shell, 洗衣机外壳 Washing Machine Shell, 冰箱外壳 Refrigerator body Shell, 电路板Circuit boards



### 固体垃圾 Solid Waste

生活垃圾MSW, 垃圾衍生物RDF, 医疗废弃物 Medical waste, 工业废品 Industrial waste

### 其他 Other

橡胶 Rubber, 纺织品Textile, 复合玻璃纤维制品Fiber& glass products



WT系列单轴撕碎机的设计可满足各种行业的废料回收要求,适用于塑料、纸张、木材、纤维、橡胶,生活垃圾回收处理等。可回收材料种类繁多,我们根据物料进料大小、产量以及最终产品的出料尺寸等为客户配置最优的方案。经撕碎后的物料可直接回收使用或者根据需求作进一步细化处理。该系列单轴撕碎机采用西门子编程控制系统,可以自动控制、设有启动、停止、反转及超载自动反转控制功能,具有低速、大扭矩,低噪音等特点。

The WT series single shaft shredder is available to recycle wide range of material.It is an ideal machine for plastics,paper,wood,fiber,rubber,organic waste a wide variety of non metallic materials.As per our customer's requirements,such as the input size of the material,capacity and the final output size etc,we could work out a suitable proposal for our clients.After being shredded by the machine,the output material could be used directly or go into the next step of size reduction.With the function of Siemens microcomputer control system,it is possible to control automatically start,stop,automatic reverse sensors to protect the machine against over loading and jamming.

## 特点 | KEY FEATURES

### CE CERTIFIED

机械、电器多重保护，符合欧盟CE标准。  
Safety devices in line with European CE Certification.



### 喂料装置

#### RAM

通过液压控制，推料箱反复将要撕碎物料推向刀滚。  
The hydraulic ram pushes material against the rotor.

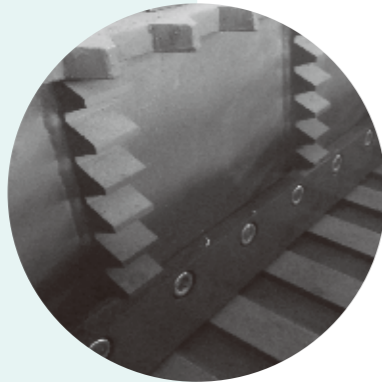

### 筛网

#### SCREEN

不同的筛网尺寸与形式，符合客户物料需求。  
Different screen size



### 刀滚

#### ROTOR

根据撕碎不同的物料配置不同类型的刀滚。刀具材料为D2，四个角可换用。  
Various rotor configurations available for processing a wide range of materials. Blades are made from hardened D2 steel, the blades can be turned 4 times before changing.



### 动刀

#### ROTOR-KNIFE

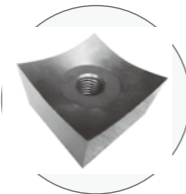

### 减震器

#### SHOCK ABSORBER

减缓撕碎过程中产生的震动，使其平稳撕碎，并安装微型继电器、瞬间过载停机保护设备。  
Absorbs vibrations caused by the shredding of the material. This protects the machine and its various parts from damage.



### 减速箱

#### GEAR BOX

采用硬齿面减速箱，安全平稳，配置水冷却功能。  
Water cooled gearbox guards against overloading. Hardened teeth on the reducer.



### 轴承座

#### BEARING SEAT

轴承外置，有效的避免粉尘进入轴承；设置定期加油嘴。  
Protective bearing covers to avoid foreign contamination entering the bearing housing. Grease points to release oil at intervals to increase service life.



### 液压系统

#### HYDRAULIC STATION

压力和流量可根据所撕碎的不同物料进行调整，WT40系列以上可选配双速油泵，风冷却。  
The ram pressure and timing can be adjusted to suit different materials. From WT40 series and above the machine can be fitted with wind cooled two-speed pump.



## 刀辊 | ROTOR



针对不同的材料要求，可选用不同的刀滚，正确地选择刀滚，可大大的提高设备的使用性能和生产效率。  
We can offer a variety of rotor configurations to suit different applications.

### ■ 高性能刀辊 High Performance Rotor

此类刀辊通用于PE.PP.PET材料、纸张，电线电缆等中等硬度和较软的材料撕碎。  
The rotor is our standard rotor, suitable for processing a wide range of materials at high speed. Materials include plastics, wood, paper, fibre, cable, etc.



### ■ 硬料刀辊 Hard Material Rotor

此刀辊是针对ABS.PC.尼龙等坚硬材料进行特殊设计。刀具沉入较深，单次切料较少，减少冲击，同时降低噪音。  
The rotor is designed specifically for processing hard materials such as ABS, PC, Nylon, etc. The blade holders are sub-set deeper into the shaft to reduce the impact on the blades and shaft.



### ■ 薄膜刀辊 Film Rotor

此刀辊增加了平动刀，有效的切断薄膜，可避免薄膜绕在刀滚上面，也适用于编织袋的撕碎。  
The rotor is designed specifically for processing films. Sub-set block blades in the shaft prevent film from wrapping around the rotor and hardox surface on the rotor protects the shaft against abrasion from sand and dirt.

### ■ 焊接刀座 WELDING KNIFE SEAT



### ■ 可拆刀座 ASSEMBLING KNIFE SEAT

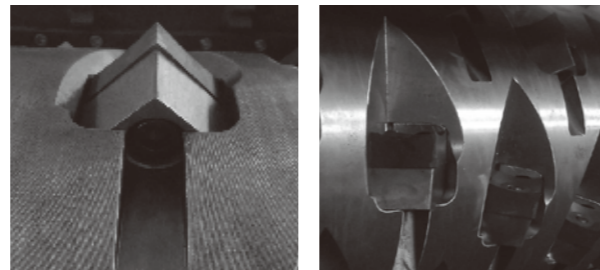

## 物料的撕碎过程 | SHREDDING PROCESS

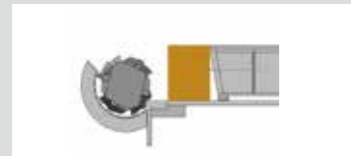

**Stage 1**  
推料箱把物料推向已经预设好转速的刀滚。  
The hydraulic ram pushes the material against the rotor at a pre-set speed.

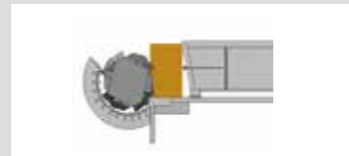

**Stage 2**  
旋转的刀具将物料切削。  
The material is shredded by the rotor teeth.

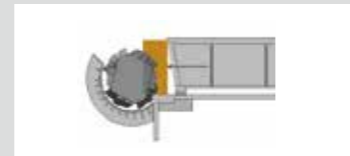

**Stage 3**  
推料箱继续把物料推向刀滚，使产量最大化。  
The hydraulic ram maintains the pressure against the rotor, maximizing output of shredded material.

## 规格 | SPECIFICATION

WT22-WT48属于常用的中小型单轴撕碎机，适用于撕碎各种形状大小不一的胶头料，塑料板材，塑料桶，PET瓶、塑料膜、纸张，电路板、橡胶、木材、家用电器、电缆等。用户可根据物料大小和处理量来选择相应的机型，也可针对不同的特殊需求选择不同的刀滚。

The WT22-WT48 range of single shaft shredders is our conventional range of small to medium size single shaft shredders. Suitable for processing a wide range of materials including: Plastic lump/purging, plastic barrels, PET bottle, films, paper, circuit boards, wood, fiber, rubber, cables and white goods.



### ■ 小型单轴撕碎机 SMALL SINGLE SHAFT SHREDDER

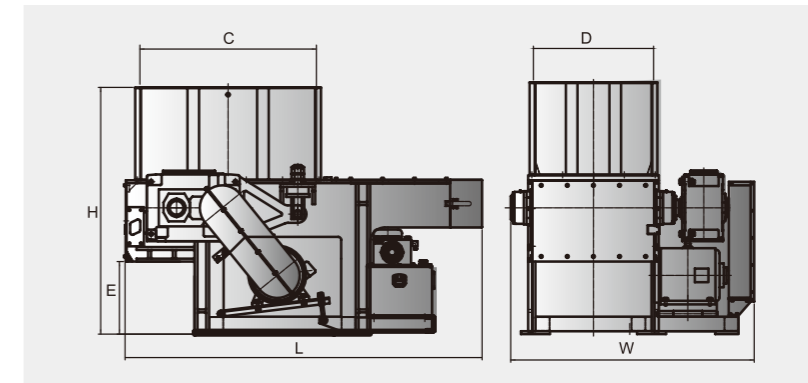

Model Item	WT2260	WT3080
外形尺寸 Dimension L/W/H(mm)	1840 X 1379 X 1754	2500 X 1712 X 1700
粉碎室尺寸 Cutting Chamber C/D(mm)	857 X 600	1200 X 800
出料口高度 Height of discharge port E(mm)	546	500
油缸行程 Cylinder Stroke(mm)	500	750
刀体回转直径 Rotor Diameter(mm)	φ224.7	φ300
主轴转速 Main Shaft Speed (r/min)	83	83
筛网孔径 Screen Mesh(mm)	φ25	φ40
动刀数量 Rotor-knives(PCS)	32	46
定刀数量 Stator-knives(PCS)	2+2	2
主机功率 Main Motor Power(KW)	18.5	30
液电功率 Hydraulic Motor Power(KW)	2.2	2.2
设备重量 Weight(KG)	Approx 1600	Approx 2600

说明:  
1.以上为机器的默认配置，筛网可按用户要求在φ20-φ100mm之间定制；薄膜撕碎机采用Z型筛网，间隙可按用户要求在20-40mm之间定制；  
2.动刀数量“+”后面的数量为平动刀数量；  
3.以上规格仅供参考，如有更改恕不另行通知。请在订购前与我司销售代表确认。

NOTICE:  
1.The above data of screen mesh is the default specification, and the diameter is available between φ20-φ100 at user's request. Film shredder adopts Z style screen which ranges between 20-40mm spaces.  
2. "+" after Rotor-knives means the quantity of the flat blade;  
3.The above specifications are only for reference and subject to change without prior notice, please confirm with our sales representative when making order.

### ■ 中型单轴撕碎机 MEDIUM SINGLE SHAFT SHREDDER

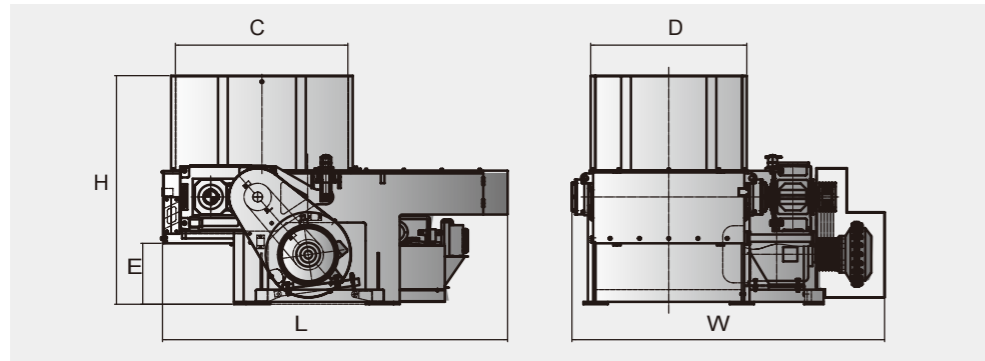

Model Item	WT4080	WT40100	WT40120	WT40150
外形尺寸Dimension L/W/H(mm)	2838 x 1779 x 1875	2838 x 2036 x 1880	2843 x 2564 x 1975	2825 x 2886 x 2103
粉碎室尺寸Cutting Chamber C/D(mm)	1410 x 800	1410 x 1000	1410 x 1200	1410 x 1500
出料口高度 Height of discharge port E(mm)	500	500	500	560
油缸行程Cylinder Stroke(mm)	900	900	900	900
刀体回转直径Rotor Diameter(mm)	φ390.3	φ390.3	φ390.3	φ390.3
主轴转速Main Shaft Speed ( r/min )	74	74	74	74
筛网孔径Screen Mesh(mm)	φ40	φ40	φ40	φ40
动刀数量Rotor-knives(PCS)	46	58	70	94
定刀数量Stator-knives(PCS)	2	2	2	3
主机功率Main Motor Power(KW)	37	45	55	75
液压电机功率Hydraulic Motor Power(KW)	2.2	2.2	5.5	5.5
设备重量Weight(KG)	Approx3300	Approx3900	Approx5400	Approx5800

Model Item	WT48150	WT48200	WT48250
外形尺寸Dimension L/W/H(mm)	3215 x 3459 x 2270	3255 x 4415 x 2720	3255 x 4465 x 2270
粉碎室尺寸Cutting Chamber C/D(mm)	1560 x 1500	1650 x 2000	1650 x 2500
出料口高度 Height of discharge port E(mm)	806	950	950
油缸行程Cylinder Stroke(mm)	1000	950	950
刀体回转直径Rotor Diameter(mm)	φ454	φ480	φ480
主轴转速Main Shaft Speed ( r/min )	74	74	74
筛网孔径Screen Mesh(mm)	φ40	φ40	φ40
动刀数量Rotor-knives(PCS)	90+4	114+4	144+4
定刀数量Stator-knives(PCS)	3	4	5
主机功率Main Motor Power(KW)	90	75+75	90+90
液压电机功率Hydraulic Motor Power(KW)	5.5	7.5	7.5
设备重量Weight(KG)	Approx 7800	Approx 12000	Approx 13000

单轴撕碎机WT4080配出料输送带/出料螺旋  
Single shaft shredder WT4080 with output conveyor/screw loader

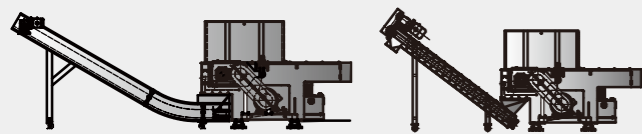

单轴撕碎机WT40100配破碎机PC4280  
Single shaft shredder WT40100 with Granulator PC4280



说明:  
1.以上为机器的默认配置, 筛网可按用户要求在φ20-φ100mm之间定制;  
薄膜撕碎机采用Z型筛网, 间隙可按用户要求在20-40mm之间定制;  
2.除WT4080、WT40100以外, 其他型号配有液力耦合器。  
3.以上规格仅供参考, 如有更改恕不另行通知。请在订购前与我司销售代表确认。

NOTICE:  
1.The above data of screen mesh is the default specification, and the diameter is available between φ20-φ100 at user's request. Film shredder adopts Z style screen which ranges between 20-40mm spaces.  
2.Except WT4080 and WT40100, other models have fluid coupling.  
3.The above specifications are only for reference and subject to change without prior notice, please confirm with our sales representative when making order.

### ■ 大型单轴撕碎机 HEAVY-DUTY SINGLE SHAFT SHREDDER

WT66系列重型单轴撕碎机, 适用于撕碎大型物料如: 电视机, 洗衣机、冰箱等电器外壳及大型管材、管件、叉车托板、轮胎、包装桶等。

The WT66 range of single shaft shredders is our large range of single shaft shredders. Suitable for shredding materials including : shell of white goods, thick walled plastic pipe, tires, barrels and etc.

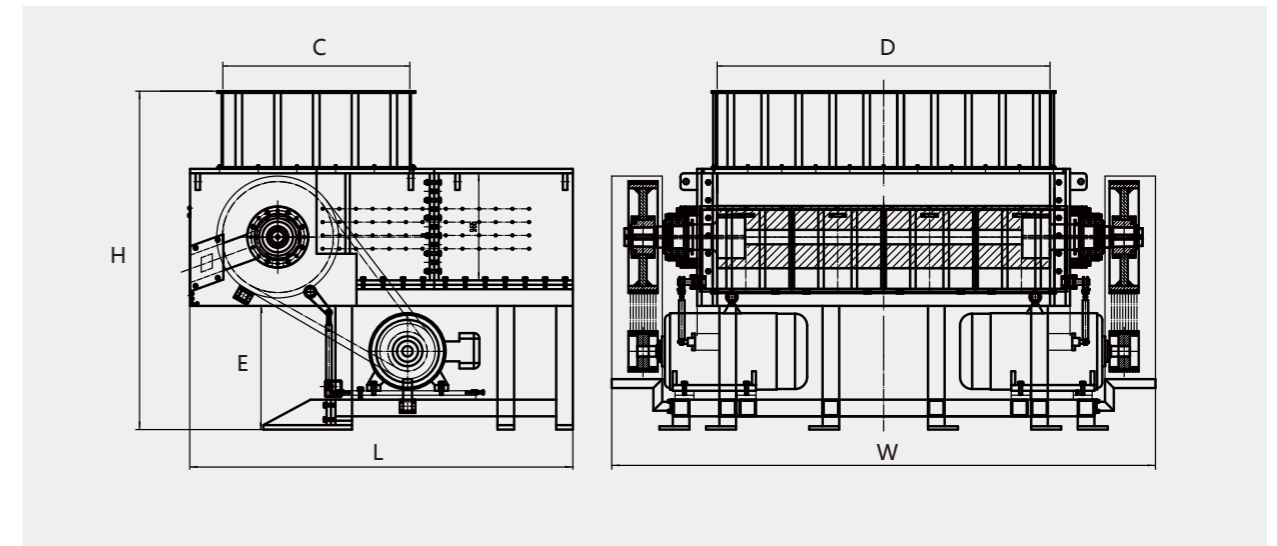

Model Item	WT66150	WT66200	WT66250	WT66300	WT66400
外形尺寸Dimension L/W/H(mm)	4100 X 3450 X 3000	4100 X 3950 X 3000	4100 X 4450 X 3000	4100 X 5500 X 3000	4100 X 6800 X 3000
粉碎室尺寸Cutting Chamber C/D(mm)	1885 X 1500	1885 X 2000	1885 X 2500	1885 X 3000	1885 X 1500
出料口高度 Height of discharge port E(mm)	1020	1020	1020	1020	1020
油缸行程Cylinder Stroke(mm)	1000	1000	1000	1000	1000
刀体回转直径Rotor Diameter(mm)	φ650	φ650	φ650	φ650	φ650
主轴转速Main Shaft Speed ( r/min )	75	75	75	75	75
筛网孔径Screen Mesh(mm)	φ40	φ40	φ40	φ40	φ40
动刀数量Rotor-knives(PCS)	126+4	158+4	225+4	291+4	363+4
定刀数量Stator-knives(PCS)	3	4	3	6	8
主机功率Main Motor Power(KW)	75+75	90+90	110+110	132+132	160+160
液压电机功率Hydraulic Motor Power(KW)	7.5	11	11	15	15
设备重量Weight(KG)	Approx 12000	Approx 13000	Approx 18000	Approx 22000	Approx 28500

说明:  
1.以上为机器的默认配置, 筛网可按用户要求在φ20-φ100mm之间定制;  
薄膜撕碎机采用Z型筛网, 间隙可按用户要求在20-40mm之间定制;  
2.动刀数量“+”后面的数量为平动刀数量;  
3.以上规格仅供参考, 如有更改恕不另行通知。请在订购前与我司销售代表确认。

NOTICE:  
1.The above data of screen mesh is the default specification, and the diameter is available between φ20-φ100 at user's request. Film shredder adopts Z style screen which ranges between 20-40mm spaces.  
2. "+" after Rotor-knives means the quantity of the flat blade;  
3.The above specifications are only for reference and subject to change without prior notice, please confirm with our sales representative when making order.

### ■ 摆臂式单轴撕碎机 SWINGING ARM SINGLE SHAFT SHREDDER

该系列适用于撕碎大型物料，如：电视机、洗衣机、冰箱等电器外壳，及大型管材、管件，叉车托板、轮胎、包装桶等。

The WTB range is swinging arm shredder which uses gravity to guide material onto the shaft.

Suitable for processing a wide range of materials including: Refrigerator ,tires,washing machine,copper, pipe,barrels,aluminum,pallets.

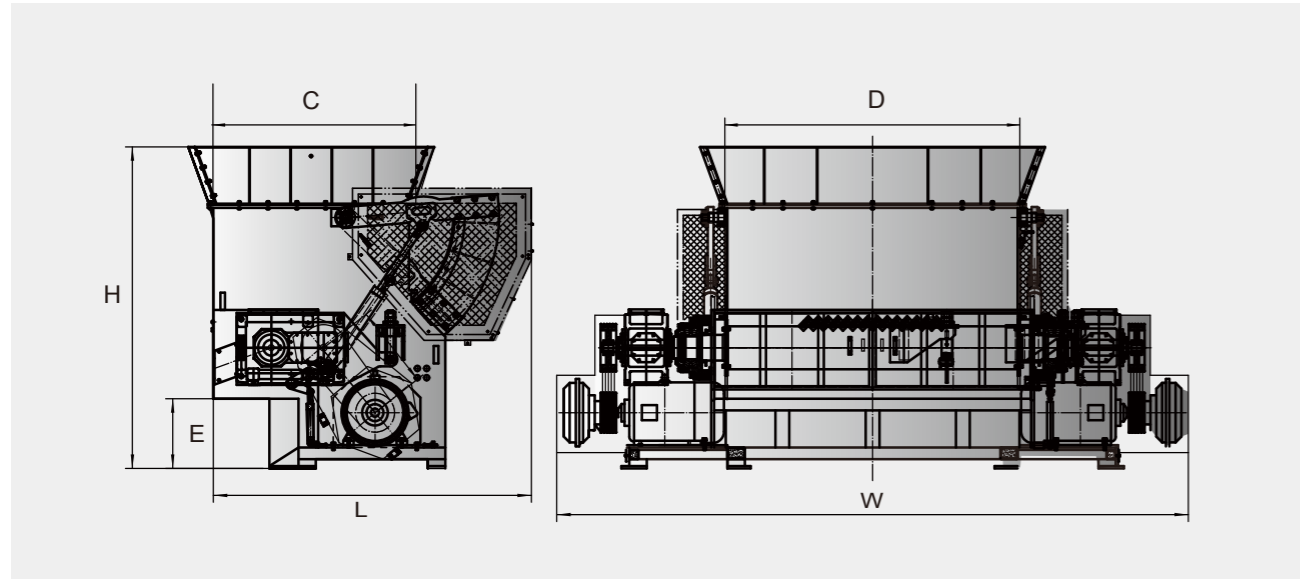

Model Item	WTB48150	WTB48200	WTB48250
外形尺寸Dimension L/W/H(mm)	2740 X 3570 X 2770	2740 X 4265 X 2770	2740 X 4930 X 2770
粉碎室尺寸Cutting Chamber C/D(mm)	1500 X 1618	2000 X 1618	2500 X 1618
出料口高度 Height of discharge port E(mm)	600	600	480
油缸行程Cylinder Stroke(mm)	550	550	550
刀体回转直径Rotor Diameter(mm)	φ464.8	φ464.8	φ464.8
主轴转速Main Shaft Speed ( r/min )	83	83	83
筛网孔径Screen Mesh(mm)	φ40	φ40	φ40
动刀数量Rotor-knives(PCS)	90+4	114+4	144+4
定刀数量Stator-knives(PCS)	3	4	5
主机功率Main Motor Power(KW)	90	75+75	90+90
液压电机功率Hydraulic Motor Power(KW)	5.5	7.5	7.5
设备重量Weight(KG)	Approx 9500	Approx 12000	Approx 15000

说明:  
1.以上为机器的默认配置，筛网可按用户要求在φ20-φ100mm之间定制；  
薄膜撕碎机采用Z型筛网，间隙可按用户要求在20-40mm之间定制；  
2.动刀数量“+”后面的数量为平动刀数量；  
3.以上规格仅供参考，如有更改恕不另行通知。请在订购前与我司销售代表确认。

NOTICE:  
1.The above data of screen mesh is the default specification, and the diameter is available between φ20-φ100 at user's request. Film shredder adopts Z style screen which ranges between 20-40mm spaces.  
2. "+" after Rotor-knives means the quantity of the flat blade;  
3.The above specifications are only for reference and subject to change without prior notice, please confirm with our sales representative when making order.

### ■ RDF高速撕碎机 RDF SINGLE SHAFT SHREDDER

RDF高速撕碎机采用优质合金钢刀具，大间距V型排布，中高速、大转矩，根据物料成分的不同，处理量可以达到3-15吨/小时，特别适合预处理过的RDF城市生活垃圾、预碎过的纺织品布料、塑料膜、木材等物料的破碎及大产量配置需求。

The blades of RDF high-speed shredder are made by good quality alloy steel, and the blades are installed on the shaft by V type with large space. With high rotor speed, large torque, it could process different material.

The capacity of the machine could reach 3 to 15ton/h, and it is specially suitable to process pre-processed municipal solid waste,pre-shred textile,plastic film, and wood material ect.

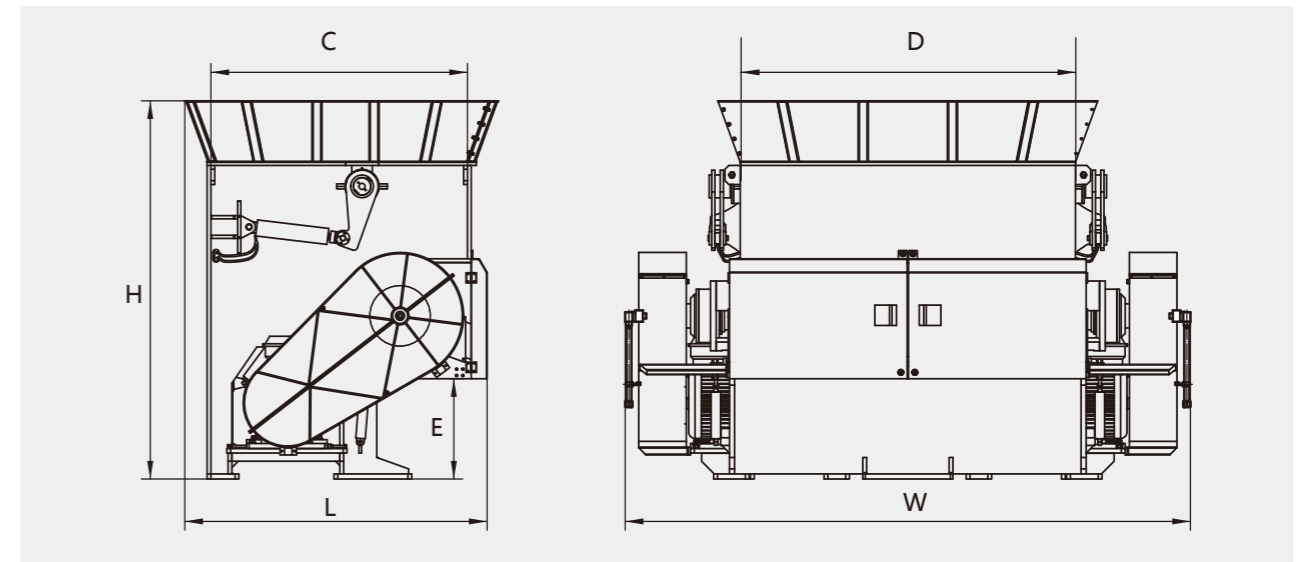

Model Item	WTB48150R	WTB48200R	WTB48250R	WTB66300R
外形尺寸Dimension L/W/H(mm)	3093 X 3450 X 2980	3093 X 3950 X 2980	3162 X 4452 X 2980	3275 X 4860 X 3170
粉碎室尺寸Cutting Chamber C/D(mm)	1500 X 1980	2000 X 1980	2500 X 1980	3000 X 1980
出料口高度 Height of discharge port E(mm)	790	790	790	950
油缸行程Cylinder Stroke(mm)	330	330	330	330
刀体回转直径Rotor Diameter(mm)	φ480	φ480	φ480	φ650
筛网孔径Screen Mesh(mm)	φ50	φ50	φ50	φ60
动刀数量Rotor-knives(PCS)	51	69	87	140
定刀数量Stator-knives(PCS)	36	46	56+4	68
主机功率Main Motor Power(KW)	110	90+90	110+110	160+160
液压电机功率Hydraulic Motor Power(KW)	7.5	11	11	15
设备重量Weight(KG)	Approx 10000	Approx 17000	Approx 21000	Approx 25000

说明:  
1.以上为机器的默认配置，筛网可按用户要求在φ20-φ100mm之间定制；  
薄膜撕碎机采用Z型筛网，间隙可按用户要求在20-40mm之间定制；  
2.动刀数量“+”后面的数量为平动刀数量；  
3.以上规格仅供参考，如有更改恕不另行通知。请在订购前与我司销售代表确认。

NOTICE:  
1.The above data of screen mesh is the default specification, and the diameter is available between φ20-φ100 at user's request. Film shredder adopts Z style screen which ranges between 20-40mm spaces.  
2. "+" after Rotor-knives means the quantity of the flat blade;  
3.The above specifications are only for reference and subject to change without prior notice, please confirm with our sales representative when making order.